1. TECHNICAL INSTALLATION

1.1 PIN Codes



TIP

- In order to enter the programming unit of **operator** and **principal user**, you have to know following codes:

1.1.1 Operator

- Push the stop key (K) and release it, thereafter push ↑↑↑↓↑.

Now you can run through the programming unit with the arrow keys (M)↓ or (N)↑. If you wish you make an adjustment, first push one of the selection buttons (G, H, I, J).

1.1.2 Principal user

- Continuously push the stop key (K) and the same time push the following keys ↑↑↑↓↑.

1.1.3 Service technician

- Continuously push the stop key (K) and the same time push the following keys ↑↑↑↓↑.
- Push upper push-button (G) for 30 seconds.

1.2 Programming carousel service technician

The screen now shows behind button G: 1.



TIP

- Options 1 – 5 (resp. §1.2.1 – §1.2.5) look and function the same.
- With (M)↓ and (N)↑ a choice can be made from options 1 – 9 (resp. §1.2.1 – §1.2.9).

1.2.1 Putting a customer-specific adjustment in memory

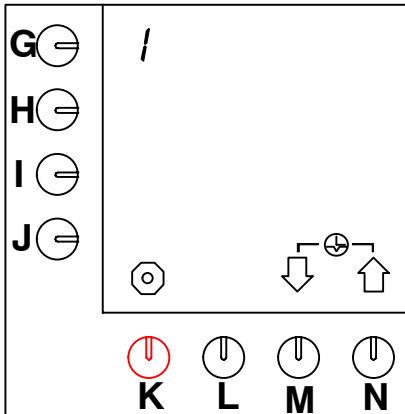

- Push button G
 - digit 1 will blink and the reset symbol $\text{---}\oplus\text{---}$ appears.
- Push buttons (M)↓ and (N)↑ for 10 seconds.
 - After this, the reset symbol $\text{---}\oplus\text{---}$ will disappear
 - digit 1 appears, indicating that the adjustment has been made.

1.2.2 Showing customer-specific adjustments

When option 1 has not been performed, this option will show the factory settings.

1.2.3 Back to the factory settings

1.2.4 Setting the descale counter(s) to 0 (after service)

1.2.5 Setting the total counter(s) to 0



TIP

- The options 6 – 9 (resp. §1.2.6 – §1.2.9) have a different operation method. These can be interrupted (before confirmed by ENTER ↵) by pushing the STOP button.

1.2.6 Activating preference (B HW)

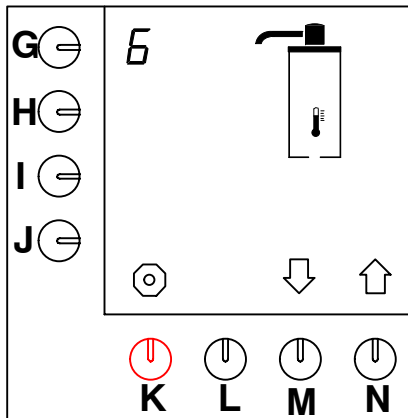

- Push button G
 - digit 6 blinks, indicating that this option can be adjusted.
- By pushing buttons (M)↓ and (N)↑ you choose:
 - A. swivel arm + thermometer on
 - B. swivel arm relieved by thermometer blinking
 - for resp. switching on or off the preference option.
- Confirm by ENTER↵
 - Digit 6 will appear and stays visible in this setting.

1.2.7 Switch off container signal

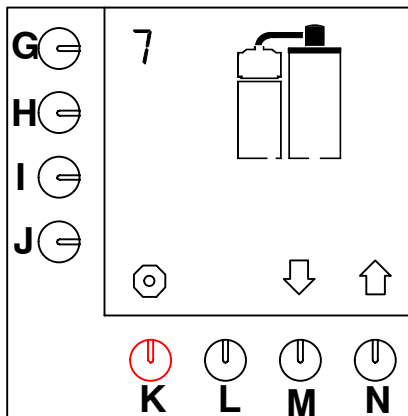

- Push button G
 - digit 7 blinks.
- By pushing buttons (M)↓ and (N)↑ you choose:
 - A. container visible
 - B. container not visible
 - for resp. switching on or off the container signal.
- Confirm by ENTER↵
 - Digit 7 will appear and stays visible in this setting.

1.2.8 Switching off the swivel arm safety during the descale programme

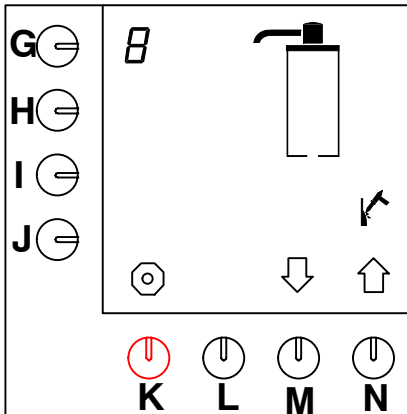

- Push button G
 - digit 8 blinks.
- By pushing buttons (M)↓ and (N)↑ you choose:
 - A. swivel arm visible
 - B. swivel arm not visible
 - for resp. switching on or off the swivel arm safety (only during the descale programme!).
- Confirm by ENTER ↵.
 - Digit 8 will appear and stays visible in this setting.

1.2.9 Selecting a machine type

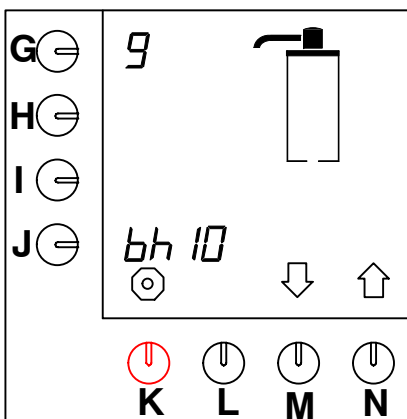

The print automatically detects whether the machine is a B or B HW version. There has to be indicated whether it concerns a 5, 10, 20 or 40 ltrs version (standard 5).

- Push button J
 - machine indication blinks.
- By pushing buttons (M)↓ and (N)↑ an other machine type can be chosen.
- Confirm by ENTER ↵.